



PRODUCT SPECIFICATION

6222Z-R

Wi-Fi Single-band 1x1 802.11b/g/n + BLE5.0 IOT

Combo Module

Version:v1.4

Customer: _____

Customer P/N: _____

Signature: _____

Date: _____

Office: 14th floor, Block B, phoenix zhigu, Xixiang Street, Baoan District, Shenzhen

Factory: NO.8, Litong RD., Liuyang Economic & Technical Development Zone, Changsha, CHINA

TEL: +86-755-2955-8186

Website: www.fn-link.com

6222Z-R Module Datasheet

Ordering Information	Part NO.	Description
	FG6222ZRXX-00	RTL8722CSM,b/g/n,Wi-Fi+BLE5.0,1T1R,20X28mm,Uart+USB, with shielding



CONTENTS

1. General Description	5
1.1 Introduction	5
1.2 Description	5
2. Features	6
3. Block Diagram	6
4. General Specification	7
4.1 WI-FI Specification	7
4.2 Bluetooth Specification	8
5. ID setting information	8
6. Pin Definition	9
6.1 Pin Outline	9
6.2 Pin Definition details	9
7. Electrical Specifications	12
7.1 Power Consumption	12
7.2 Interface Circuit time series	13
8. Size reference	14
8.1 Module Picture	14
8.2 Marking Description	14
8.3 Physical Dimensions	15
8.4 Layout Recommendation	16
9. The Key Material List	16
10. Reference Design	17
11. Recommended Reflow Profile	18
12. Package	19
12.1 Reel	19
12.2 Carrier Tape Detail	19
12.3 Packaging Detail	20
13. Moisture sensitivity	21

1. General Description

1.1 Introduction

RTL8722CSM is a highly integrated single-chip low power single bands (2.4GHz) Wireless LAN (WLAN) and Bluetooth Low Energy (BLE 5.0) communication controller. It consists of a high performance MCU (Armv8-M, Cortex-M33 instruction set compatible) called Real-M300 (or KM4 thereafter) and a low power MCU (Armv8-M, Cortex-M23 instruction set compatible) called Real-M200 (or KM0 thereafter), WLAN (802.11 b/g/n) MAC, an 1T1R capable WLAN baseband, RF, Bluetooth and peripherals.

High speed connectivity interfaces, SDIO and USB are provided. Also audio codec, key-scan and touch keys integrated. Flexible design configures GPIO to different functions.

6222Z-R integrates internal memories for complete Wi-Fi protocol functions.

1.2 Description

Model Name	6222Z-R
Product Description	Support Wi-Fi/Bluetooth functionalities
Dimension	L x W x H: 20 x 28 x3.35 mm
Host Interface	UART,USB,SD, SDIO ,SPI,I2C...
OS supported	Android /Linux/ Win CE /iOS /XP/WIN7/WIN10
Operating temperature	-20°C to 85°C
Storage temperature	-40°C to 125°C

2. Features

General

- Supports 20MHz/40MHz up to MCS7,802.11 b/g/n 1x1, 2.4GHz

Host Interface

- Support SDIO 2.0/SD/USB/SPI/UART/I2C/USI/IR/SGPIO

Bluetooth Features

- Support Bluetooth 5.0
- High power mode (8dbm, shares the same PA with Wi-Fi)
- Internal co-existence mechanism between Wi-Fi and BT to share the same antenna

3. Block Diagram

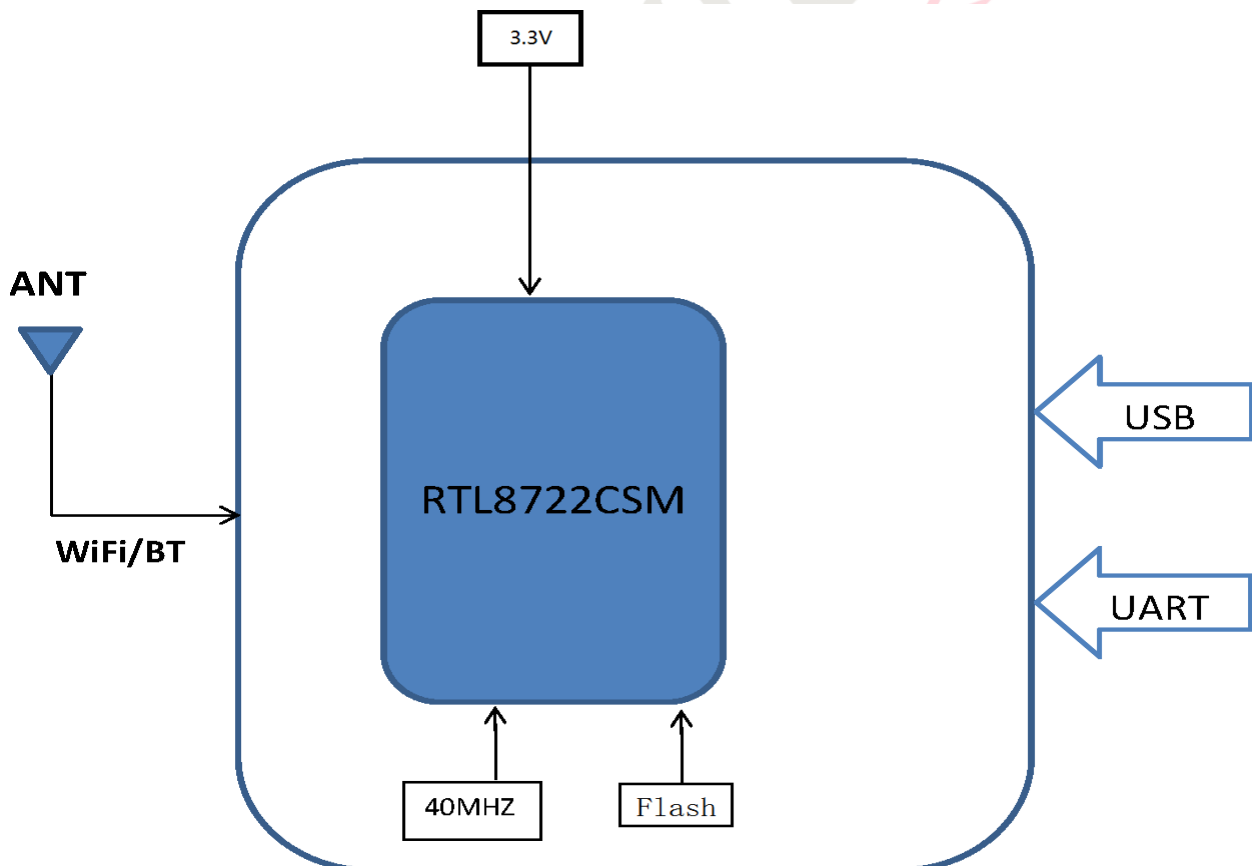

4. General Specification

4.1 WI-FI Specification

Feature	Description	
WLAN Standard	IEEE 802.11 b/g/n Wi-Fi compliant	
Frequency Range	2.400 GHz ~ 2.4835 GHz (2.4 GHz ISM Band)	
Number of Channels	2.4GHz: Ch1 ~ Ch14	
Test Items	Typical Value	EVM
Output Power	802.11b /11Mbps : 18dBm ± 2 dB	EVM ≤ -10dB
	802.11g /54Mbps : 17dBm ± 2 dB	EVM ≤ -25dB
	802.11n /MCS7 : 16dBm ± 2 dB	EVM ≤ -28dB
Spectrum Mask	Meet with IEEE standard	
Freq. Tolerance	± 20ppm	
SISO Receive Sensitivity (11b,20MHz) @8% PER	- 1Mbps PER @ -94 dBm	≤-83 dBm
	- 2Mbps PER @ -92 dBm	≤-80 dBm
	- 5.5Mbps PER @ -89 dBm	≤-79 dBm
	- 11Mbps PER @ -87 dBm	≤-76 dBm
Receive Sensitivity (11g,20MHz) @10% PER	- 6Mbps PER @ -89 dBm	≤-85 dBm
	- 9Mbps PER @ -88 dBm	≤-84 dBm
	- 12Mbps PER @ -87 dBm	≤-82 dBm
	- 18Mbps PER @ -86 dBm	≤-80 dBm
	- 24Mbps PER @ -84 dBm	≤-77 dBm
	- 36Mbps PER @ -80 dBm	≤-73 dBm
	- 48Mbps PER @ -77 dBm	≤-69 dBm
	- 54Mbps PER @ -75 dBm	≤-68 dBm
Receive Sensitivity (11n,20MHz) @10% PER	- MCS=0 PER @ -89 dBm	≤-85 dBm
	- MCS=1 PER @ -86 dBm	≤-82 dBm
	- MCS=2 PER @ -84 dBm	≤-80 dBm
	- MCS=3 PER @ -82 dBm	≤-77 dBm
	- MCS=4 PER @ -79 dBm	≤-73 dBm
	- MCS=5 PER @ -76 dBm	≤-69 dBm
	- MCS=6 PER @ -74 dBm	≤-68 dBm
	- MCS=7 PER @ -72 dBm	≤-67 dBm
Receive Sensitivity (11n,40MHz) @10% PER	- MCS=0 PER @ -89 dBm	≤-82 dBm
	- MCS=1 PER @ -86 dBm	≤-79 dBm
	- MCS=2 PER @ -83 dBm	≤-77 dBm
	- MCS=3 PER @ -80 dBm	≤-74 dBm
	- MCS=4 PER @ -77 dBm	≤-70 dBm
	- MCS=5 PER @ -74 dBm	≤-66 dBm

	- MCS=6 PER @ -72 dBm	≤-65 dBm
	- MCS=7 PER @ -70 dBm	≤-64 dBm
Maximum Input Level	802.11b: -10 dBm	
	802.11g/n: -20 dBm	
Antenna Reference	PCB antenna with 0~2 dBi peak gain	

4.2 Bluetooth Specification

Feature	Description		
General Specification			
Bluetooth Standard	Bluetooth V5.0		
Host Interface	UART		
Antenna Reference	Small antennas with 0~2 dBi peak gain		
Frequency Band	2400 MHz ~ 2483.5 MHz		
Number of Channels	40 channels for BLE		
Modulation	GFSK, $\pi/4$ -DQPSK		
RF Specification			
	Min(dBm)	Typical(dBm)	Max(dBm)
Output Power (Class 1)	4	6	8
Sensitive @PER=30.8%			-70
Maximum Input Level	-10 dBm		

5. ID setting information

WI-FI

Vendor ID	/
Product ID	/

6. Pin Definition

6.1 Pin Outline

< TOP VIEW

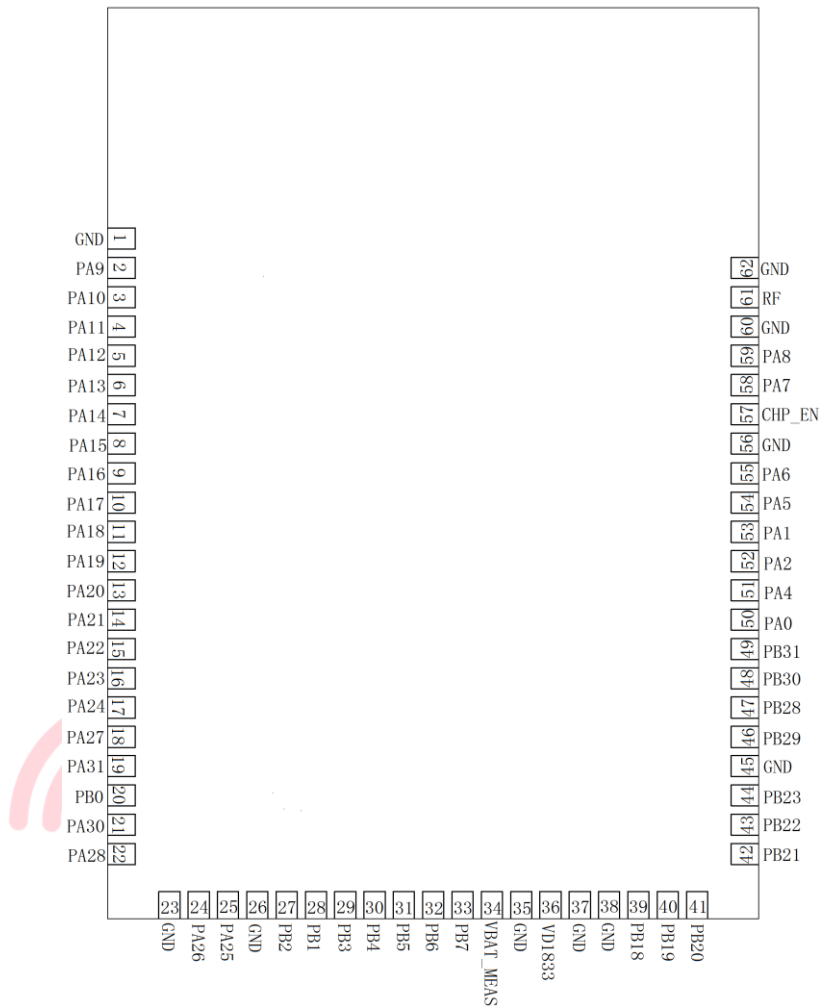

6.2 Pin Definition details

NO.	Name	Type	Description	Voltage
1	GND		Ground connections	
2	PA9	IO	GPIO Pin. The MUX Function can be referred to Pin Function Table	
3	PA10	IO	GPIO Pin. The MUX Function can be referred to Pin Function Table	
4	PA11	IO	GPIO Pin. The MUX Function can be referred to Pin Function Table	
5	PA12	IO	GPIO Pin. The MUX Function can be referred to Pin Function Table	
6	PA13	IO	GPIO Pin. The MUX Function can be referred to Pin	

			Function Table	
7	PA14	IO	GPIO Pin. The MUX Function can be referred to Pin Function Table	
8	PA15	IO	GPIO Pin. The MUX Function can be referred to Pin Function Table	
9	PA16	IO	GPIO Pin. The MUX Function can be referred to Pin Function Table	
10	PA17	IO	GPIO Pin. The MUX Function can be referred to Pin Function Table	
11	PA18	IO	GPIO Pin. The MUX Function can be referred to Pin Function Table	
12	PA19	IO	GPIO Pin. The MUX Function can be referred to Pin Function Table	
13	PA20	IO	GPIO Pin. The MUX Function can be referred to Pin Function Table	
14	PA21	IO	GPIO Pin. The MUX Function can be referred to Pin Function Table	
15	PA22	IO	GPIO Pin. The MUX Function can be referred to Pin Function Table	
16	PA23	IO	GPIO Pin. The MUX Function can be referred to Pin Function Table	
17	PA24	IO	GPIO Pin. The MUX Function can be referred to Pin Function Table	
18	PA27	IO	GPIO Pin. The MUX Function can be referred to Pin Function Table	
19	PA31	IO	GPIO Pin. The MUX Function can be referred to Pin Function Table	
20	PB0	IO	GPIO Pin. The MUX Function can be referred to Pin Function Table	
21	PA30	IO	GPIO Pin. The MUX Function can be referred to Pin Function Table	
22	PA28	IO	GPIO Pin. The MUX Function can be referred to Pin Function Table	
23	GND	IO	Ground connections	
24	PA26	IO	GPIO Pin. The MUX Function can be referred to Pin Function Table	
25	PA25	IO	GPIO Pin. The MUX Function can be referred to Pin Function Table	
26	GND	IO	Ground connections	
27	PB2	IO	GPIO Pin. The MUX Function can be referred to Pin Function Table	
28	PB1	IO	GPIO Pin. The MUX Function can be referred to Pin Function Table	
29	PB3	IO	GPIO Pin. The MUX Function can be referred to Pin Function Table	
30	PB4	IO	GPIO Pin. The MUX Function can be referred to Pin Function Table	
31	PB5	IO	GPIO Pin. The MUX Function can be referred to Pin Function Table	
32	PB6	IO	GPIO Pin. The MUX Function can be referred to Pin Function Table	
33	PB7	IO	GPIO Pin. The MUX Function can be referred to Pin Function Table	
34	VBAT_MEAS	IO	ADC input pin ,5V tolerance	
35	GND		Ground connections	
36	VD1833		3.3V/1.8V dc Power input	
37	GND		Ground connections	
38	GND		Ground connections	
39	PB18		GPIO Pin. The MUX Function can be referred to Pin	

			Function Table	
40	PB19		GPIO Pin. The MUX Function can be referred to Pin Function Table	
41	PB20		GPIO Pin. The MUX Function can be referred to Pin Function Table	
42	PB21		GPIO Pin. The MUX Function can be referred to Pin Function Table	
43	PB22		GPIO Pin. The MUX Function can be referred to Pin Function Table	
44	PB23		GPIO Pin. The MUX Function can be referred to Pin Function Table	
45	GND		Ground connections	
46	PB29		GPIO Pin. The MUX Function can be referred to Pin Function Table	
47	PB28		GPIO Pin. The MUX Function can be referred to Pin Function Table	
48	PB30		GPIO Pin. The MUX Function can be referred to Pin Function Table	
49	PB31		GPIO Pin. The MUX Function can be referred to Pin Function Table	
50	PA0		GPIO Pin. The MUX Function can be referred to Pin Function Table	
51	PA4		GPIO Pin. The MUX Function can be referred to Pin Function Table	
52	PA2		GPIO Pin. The MUX Function can be referred to Pin Function Table	
53	PA1		GPIO Pin. The MUX Function can be referred to Pin Function Table	
54	PA5		GPIO Pin. The MUX Function can be referred to Pin Function Table	
55	PA6		GPIO Pin. The MUX Function can be referred to Pin Function Table	
56	GND		Ground connections	
57	CHP_EN		Enable chip 1:Enable chip 0:Shut down chip	
58	PA7		GPIO Pin. The MUX Function can be referred to Pin Function Table	
59	PA8		GPIO Pin. The MUX Function can be referred to Pin Function Table	
60	GND		Ground connections	
61	RF		RF port	
62	GND		Ground connections	

P:POWER I:INPUT O:OUTPUT VDDIO:3.3V

7. Electrical Specifications

7.1 Power Consumption

Operation Mode		Condition	Current		Unit
Power Mode	Scenario		3.3V	1.8V	
Deepsleep	Deepsleep	RTC timer 1KB retention RAM	7~8	7.8	uA
	Deepsleep with Key-Scan	RTC timer 1KB retention RAM Key-Scan	12~13	12~13	uA
	Deepsleep with Cap-Touch	RTC timer	20	16	uA
(average current)		1KB retention RAM Cap-Touch			
Sleep	WoWLAN sleep power	KM4 power gate KM0 clock gate All RAM retained Wi-Fi retained	30~50	30~50	uA
Active	Wi-Fi Tx	CCK 18dBm @3.3V, and 15dBm @1.8V KM4 in active mode	257	224	mA
		OFDM 19dBm @3.3V, and 13dBm @1.8V KM4 in active mode	262	214	mA
	Wi-Fi Rx Idle	HT20 MCS0~7 normal mode KM4 in active mode Rx idle	50	81	mA
		HT20 MCS0~7 ultra-low power mode KM4 in active mode Rx idle	35	60	mA
	Wi-Fi Rx UDP	HT20 MCS0~7 ultra-low power mode KM4 in active mode UDP Rx @ 8Mbps	39	67	mA
WoWLAN	WoWLAN Rx Beacon	Rx beacon mode @ normal mode KM4 in sleep mode	28	45	mA
		Rx beacon mode @ ultra-low power mode KM4 in sleep mode	23	39	mA
	WoWLAN DTIM=1 (Average)	KM4 in sleep mode All SRAM retained Wi-Fi retained Shielding room	700~800	1100~1200	uA
		KM4 in sleep mode All SRAM retained Wi-Fi retained Open space	1~2	1.1~2	mA
Note: Ultra-low power mode side effect: ● OFDM: Rx Sensitivity Degree 2~4dBm ● CCK: Rx Sensitivity Degree 1~2dBm					

7.2 Interface Circuit time series

Power on or Resuming from Deepsleep Sequence

The timing sequence of power on or resuming from deepsleep is given in Fig 7-1.

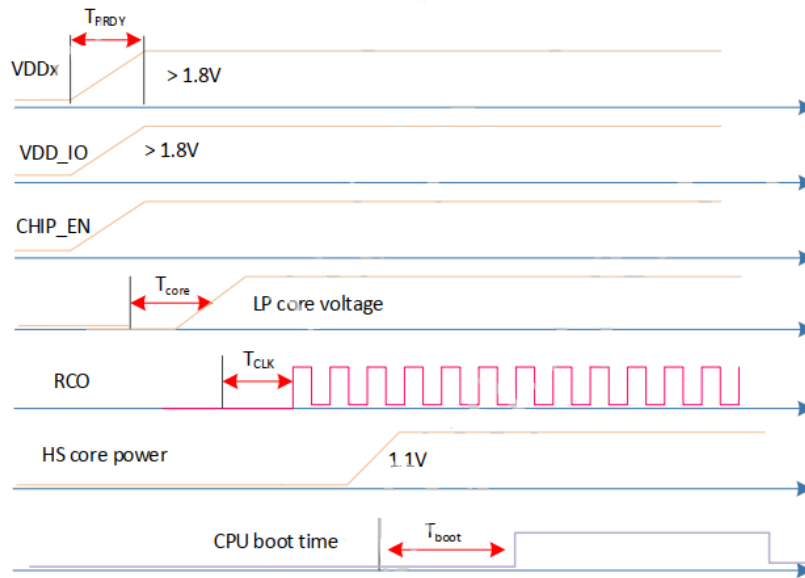

Fig 7-1 Timing sequence of power on or resuming from deepsleep

Shutdown Sequence

The timing sequence of shutdown is illustrated in Fig 7-2.

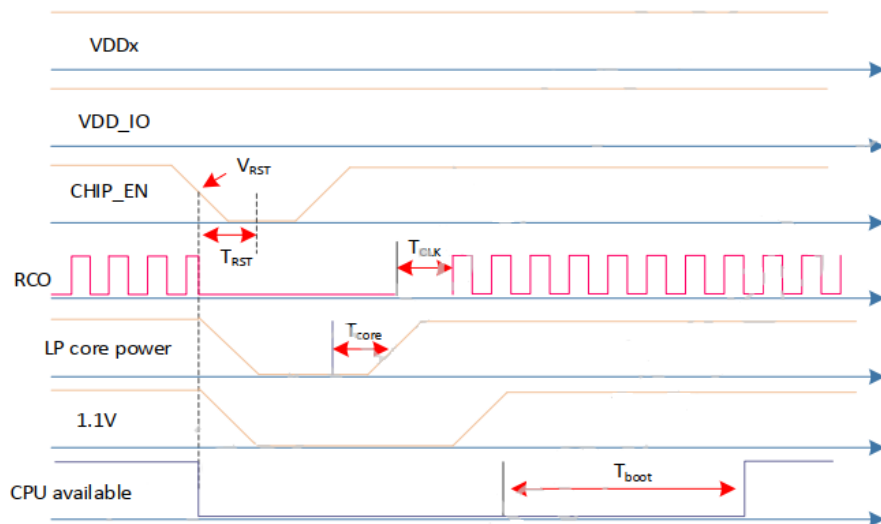
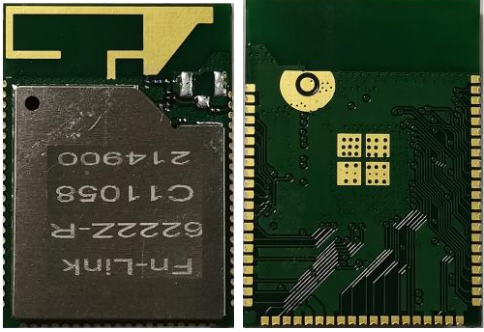
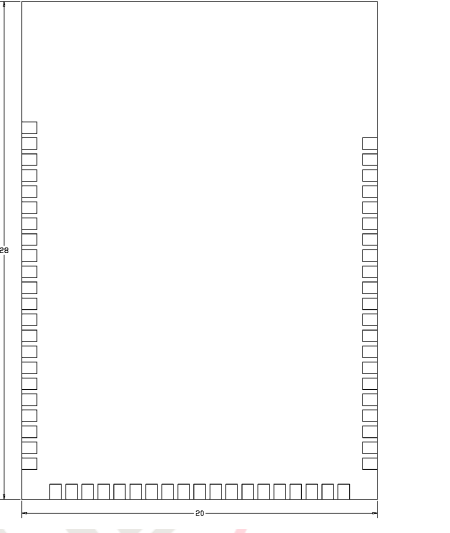
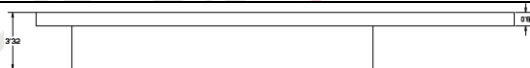

Fig 7-2 Timing sequence of shutdown

8. Size reference

8.1 Module Picture

<p>L x W : 20 x 28 (+0.3/-0.1) mm</p> 	
<p>H: 3.35 (±0.2) mm</p>	
<p>Weight</p>	<p>2.28g</p>

8.2 Marking Description

< TOP VIEW >

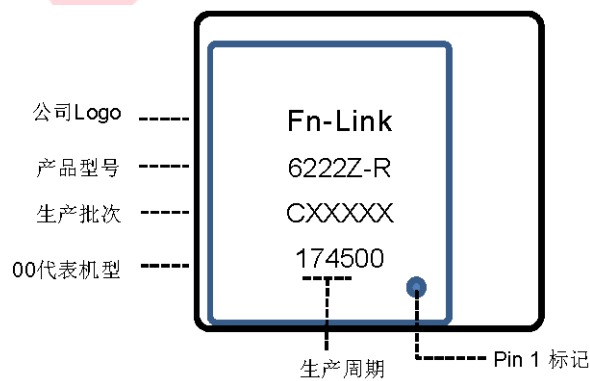

8.3 Physical Dimensions

<TOP View>

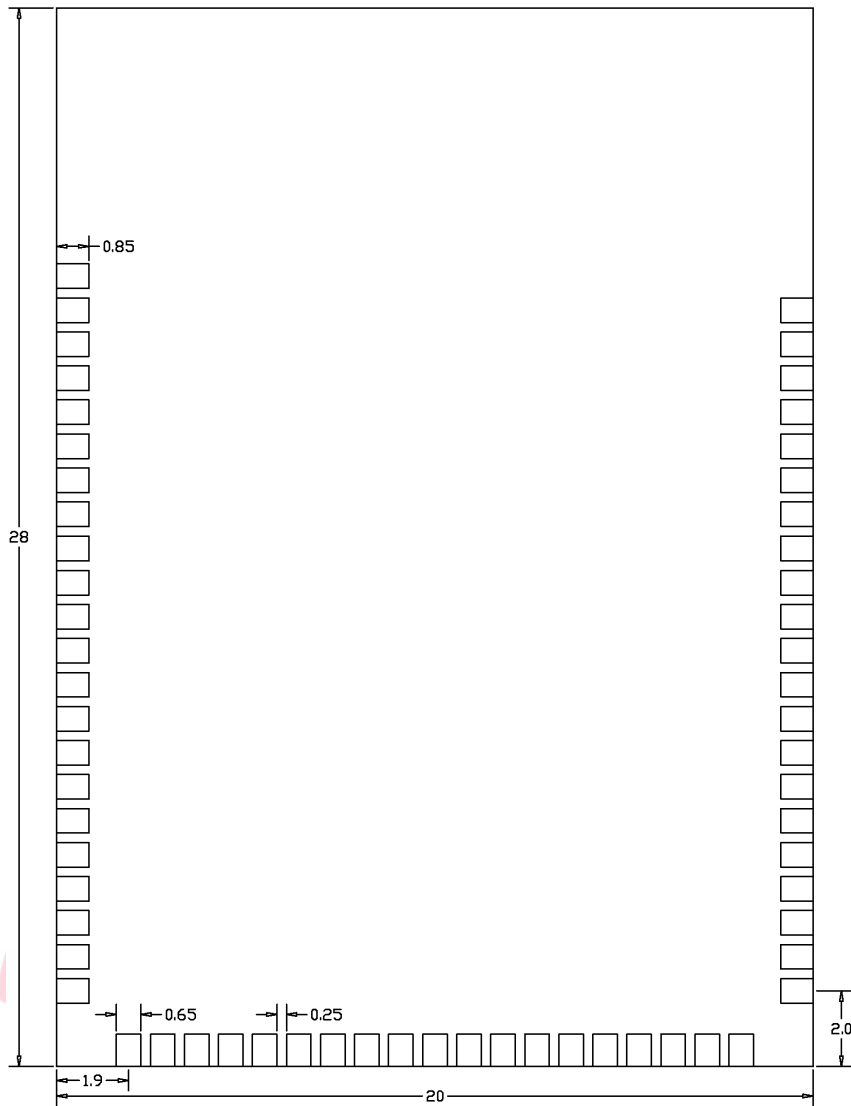

8.4 Layout Recommendation

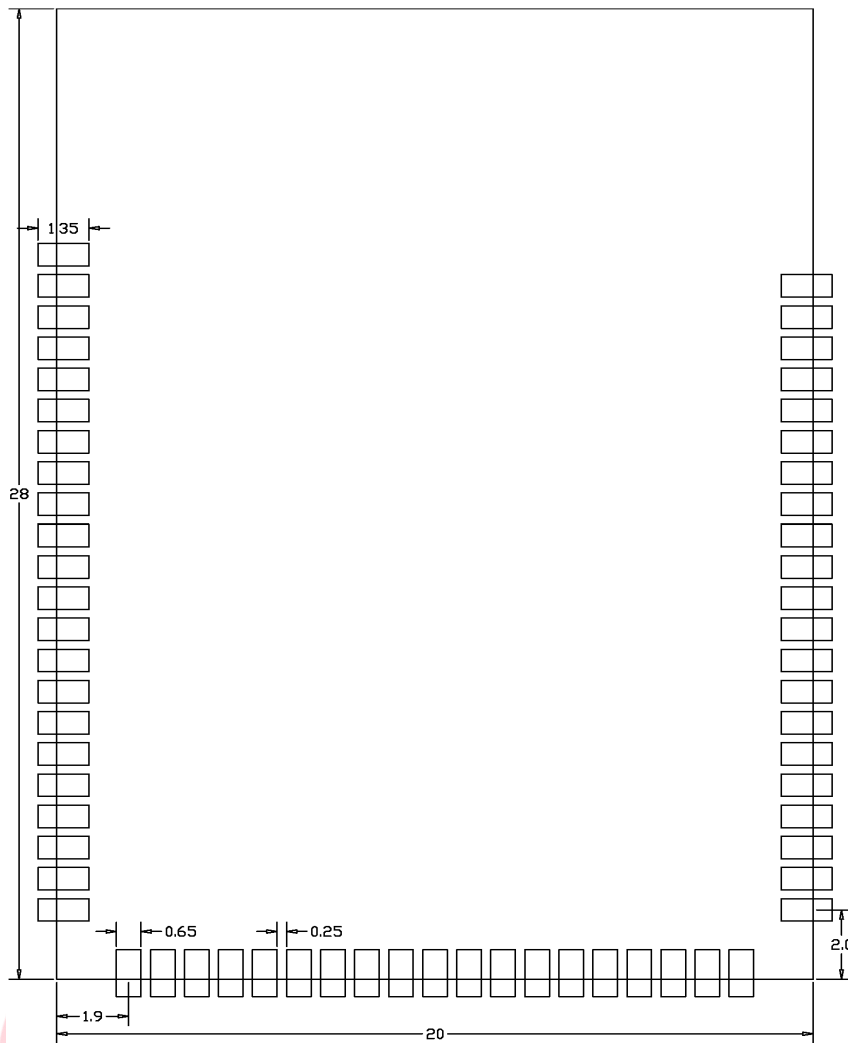

9. The Key Material List

Name	specification	supplier
Chipset	RTL8722CSM-VA1-CG QFN-88 10X10mm	Realtek
PCB	6222Z-R bottle green, 4L, FR4, 28X20X0.8mm	XY-PCB, KX-PCB, SL-PCB, Sunlord
Crystal	2016 40MHZ,15PF,±10PPM,-30-85℃ Y40000V023	TST, HOSONIC, TKD, ECEC, JWT
Inductor	0805 2.2UH,±20%,1.5A,BDCD002016102R2ML1	Microgate, sunlord, cenke, ceaiya, Chilisin
Shielding	6222Z-R shielding	信太, 精力通

10. Reference Design

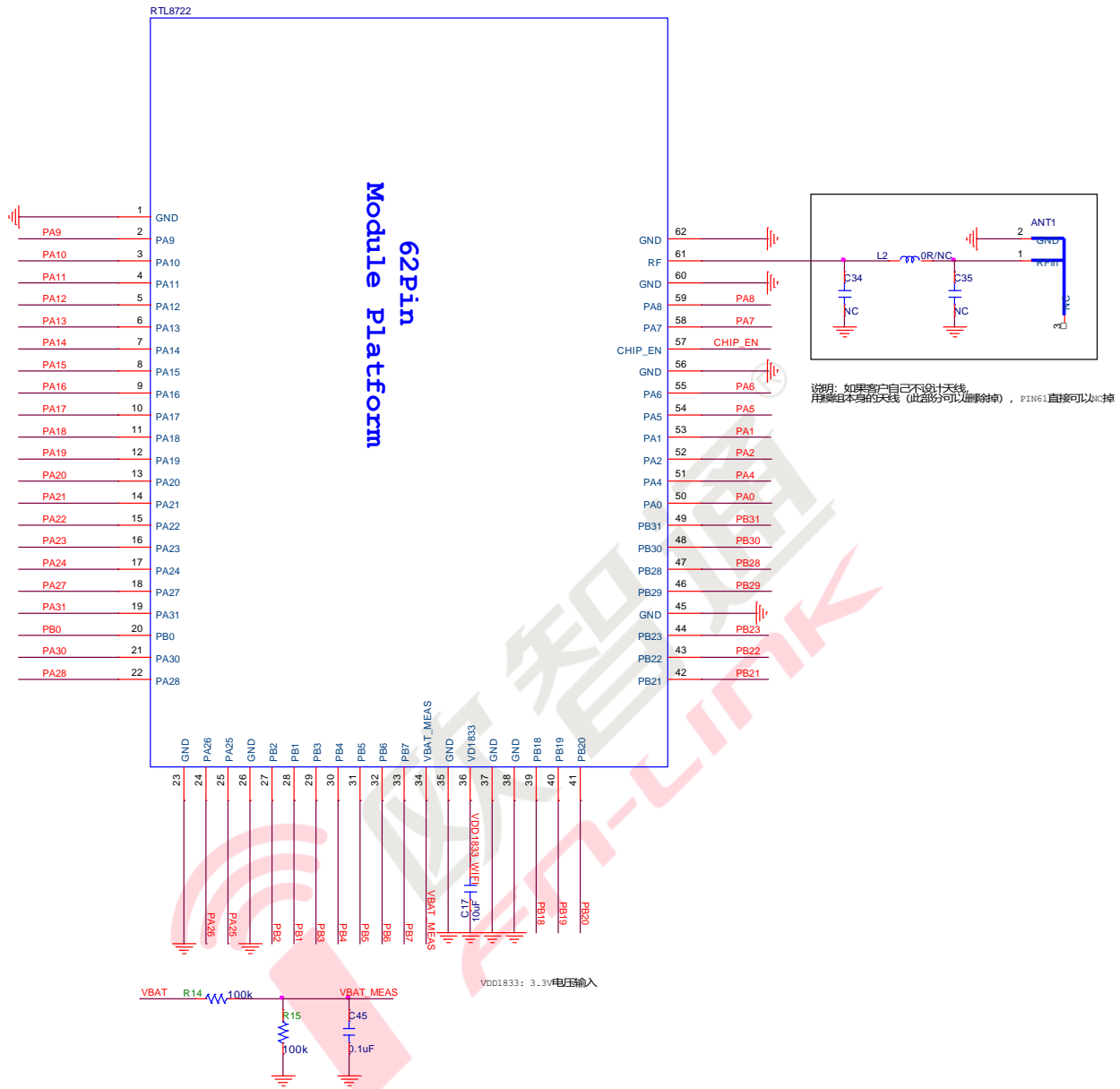

11. Recommended Reflow Profile

Referred to IPC/JEDEC standard.

Peak Temperature : <250°C

Number of Times : ≤2 times

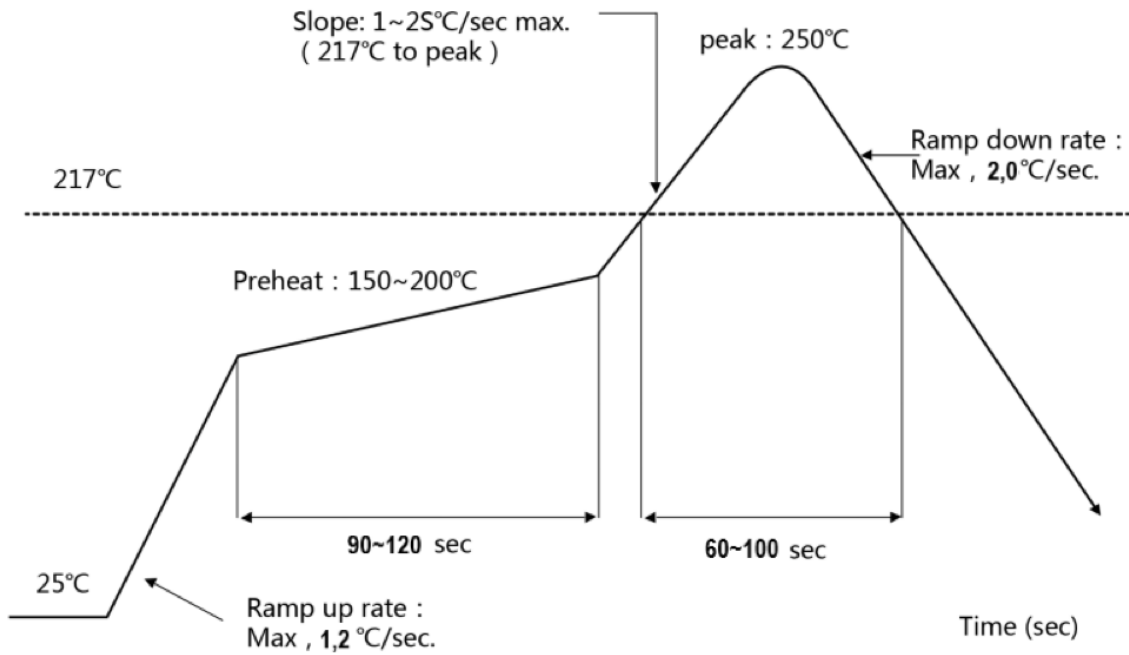

12. Package

12.1 Reel

A roll of 500pcs

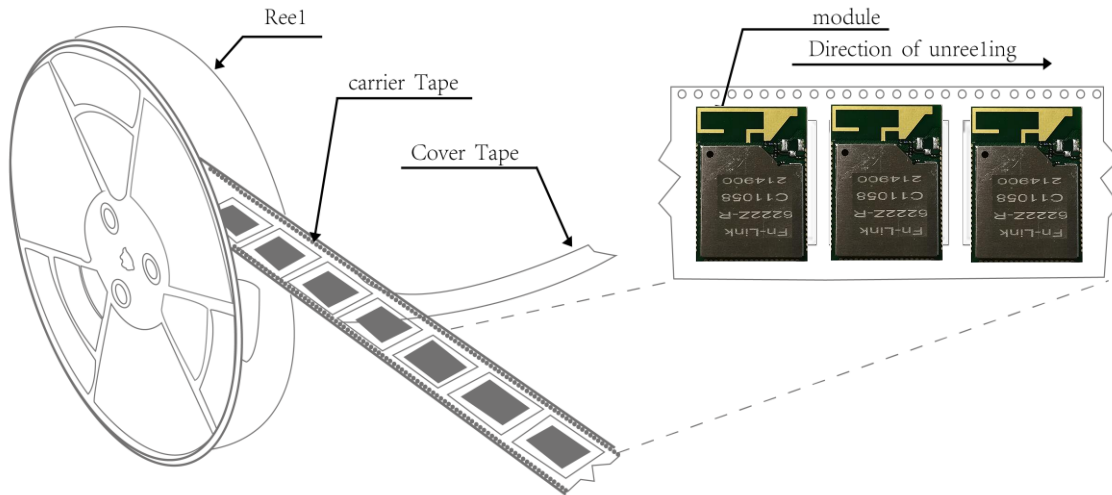

12.2 Carrier Tape Detail

ITEM	W	A0	B0	D	E	F	F1	K0	P0	P2	P	T
DIM	44	20.40	28.35	1.5	1.75	20.2	40.4	3.80	4.0	2.0	28.0	0.30
TOLE	$^{+0.3}_{-0.3}$	± 0.15	± 0.15	$^{+0.1}_{-0.0}$	± 0.1	± 0.15	± 0.10	± 0.10	± 0.1	± 0.15	± 0.1	± 0.05

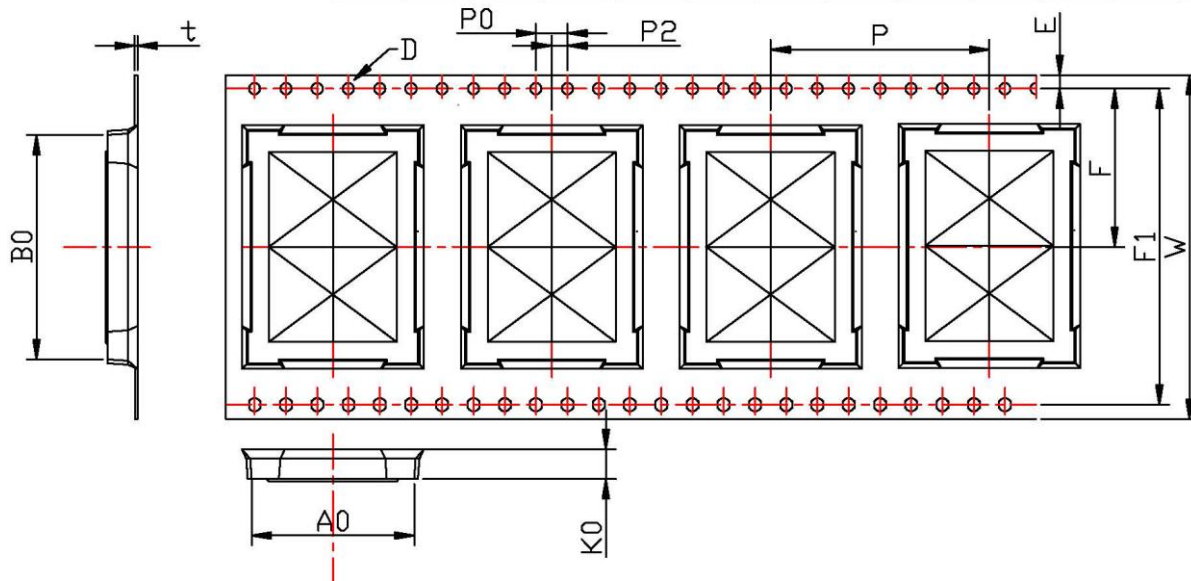

12.3 Packaging Detail

the take-up package



Using self-adhesive tape

Width of black tape: 44mm

the cover tape :37.5mm

Color of plastic disc: black



NY bag size:500mm*420mm



size : 335X335X55mm



The packing case size:360*210*370mmg

13. Moisture sensitivity

The Modules is a Moisture Sensitive Device level 3, in according with standard IPC/JEDEC J-STD-020, take care

all the relatives requirements for using this kind of components.

Moreover, the customer has to take care of the following conditions:

- a) Calculated shelf life in sealed bag: 12 months at <math><40^{\circ}\text{C}</math> and <math><90\%</math> relative humidity (RH)
- b) Environmental condition during the production: - c) The maximum time between the opening of the sealed bag and the reflow process must be 168 hours if condition
- b) "IPC/JEDEC J-STD-033A paragraph 5.2" is respected
- d) Baking is required if conditions b) or c) are not respected
- e) Baking is required if the humidity indicator inside the bag indicates 10% RH or more